



US007845344B2

(12) **United States Patent**
Sorenson et al.

(10) **Patent No.:** **US 7,845,344 B2**
(45) **Date of Patent:** **Dec. 7, 2010**

(54) **INCLUSIVE SINGLE-USE HEATING DEVICE**

(75) Inventors: **Chad M. Sorenson**, Oregon, WI (US);
David C. Franchino, Madison, WI (US);
Mark Schweiger, Madison, WI (US);
Tom Bush, Madison, WI (US)

(73) Assignee: **Sologear, LLC**, Madison, WI (US)

(*) Notice: Subject to any disclaimer, the term of this patent is extended or adjusted under 35 U.S.C. 154(b) by 0 days.

2,562,647 A *	7/1951	Shaver	222/480
2,619,951 A	12/1952	Kahn	
2,669,914 A	2/1954	Swaine	
2,673,003 A	3/1954	Stewart	
2,673,806 A	3/1954	Colman	
2,733,709 A *	2/1956	Sukacev	126/262
2,746,378 A	5/1956	Lang	
2,772,627 A	12/1956	Newell	
2,834,661 A	5/1958	Chaplin	
2,842,116 A	7/1958	Hinderer	
2,875,683 A	3/1959	Burns	

(21) Appl. No.: **12/038,362**

(22) Filed: **Feb. 27, 2008**

(65) **Prior Publication Data**

US 2008/0202489 A1 Aug. 28, 2008

Related U.S. Application Data

(60) Provisional application No. 60/891,848, filed on Feb. 27, 2007.

(51) **Int. Cl.**
A47G 23/04 (2006.01)

(52) **U.S. Cl.** **126/246**; 126/43; 126/262;
431/331; 431/341

(58) **Field of Classification Search** 126/246,
126/43, 262; 431/331, 341
See application file for complete search history.

(56) **References Cited**

U.S. PATENT DOCUMENTS

790,612 A *	5/1905	Boniface	126/246
1,104,383 A *	7/1914	Potter	431/341
1,226,625 A *	5/1917	Ball	431/331
1,542,852 A *	6/1925	Busch	126/43
1,995,049 A *	3/1935	Zeitz	431/342
2,034,478 A *	3/1936	Levy	62/457.6
2,036,739 A *	4/1936	Arnold	222/459
2,302,984 A	11/1942	Tollzien	
2,334,847 A	11/1943	Spiers	

(Continued)

FOREIGN PATENT DOCUMENTS

WO WO 2006/107983 10/2006

(Continued)

OTHER PUBLICATIONS

United States Office Action for U.S. Appl. No. 11/398,579 dated May 30, 2008 (9 pages).

(Continued)

Primary Examiner—Kenneth B Rinehart
Assistant Examiner—Jorge Pereiro
(74) *Attorney, Agent, or Firm*—Michael Best & Friedrich LLP

(57) **ABSTRACT**

The invention comprises a fuel package comprising a vessel, a fuel, a combustion-restricting choke plate and a sealed lidding.

16 Claims, 14 Drawing Sheets

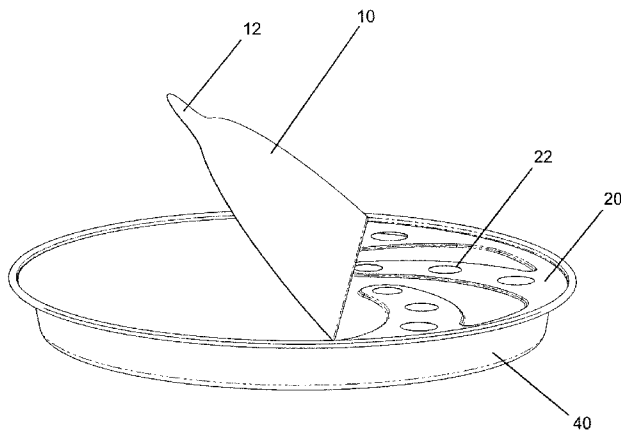

U.S. PATENT DOCUMENTS

2,918,051 A 12/1959 Broman
 2,965,096 A 12/1960 Barton
 2,965,097 A 12/1960 Clark, Jr.
 2,975,887 A * 3/1961 Weingart 206/533
 2,981,249 A 4/1961 Russel
 3,000,372 A 9/1961 Hall
 3,094,981 A * 6/1963 Brewer 126/263.05
 3,109,420 A 11/1963 Ott et al.
 3,146,773 A 9/1964 Melzer
 3,157,315 A * 11/1964 Bianco 222/142.5
 3,183,068 A 5/1965 Alexander
 3,262,445 A 7/1966 Stults et al.
 3,279,453 A 10/1966 Norehad et al.
 3,291,579 A * 12/1966 Mulasky 44/266
 3,292,608 A 12/1966 Waddell et al.
 3,353,527 A 11/1967 Anderson
 3,370,582 A 2/1968 Rauh
 3,371,659 A 3/1968 Paspalas
 3,385,282 A 5/1968 Lloyd
 3,394,693 A 7/1968 Robinson
 3,407,803 A 10/1968 Cervenak
 3,428,039 A 2/1969 Desmoulins
 3,478,733 A 11/1969 Meyerhoefer
 3,491,743 A 1/1970 Temp
 3,509,814 A 5/1970 Karapetian
 3,555,994 A 1/1971 Nemetz
 3,570,469 A 3/1971 Jones
 3,575,156 A 4/1971 Hosford
 3,583,309 A 6/1971 Freidenrich
 3,589,353 A 6/1971 Sanders
 3,606,609 A 9/1971 Lipper et al.
 3,682,154 A 8/1972 Mollere
 3,684,087 A 8/1972 Anderson
 3,769,957 A 11/1973 Ozaki
 3,774,560 A * 11/1973 Hartz 413/6
 3,841,298 A 10/1974 Sellors
 3,910,250 A 10/1975 Orsing
 3,913,557 A * 10/1975 Ewanika et al. 126/43
 3,978,782 A 9/1976 Werling
 4,100,912 A 7/1978 Doane
 4,140,099 A 2/1979 Newport
 4,150,610 A 4/1979 Ferrara
 4,254,863 A 3/1981 Katcs et al.
 4,351,314 A 9/1982 Morton
 4,394,342 A * 7/1983 Mercer 264/292
 4,436,525 A 3/1984 Zmoda et al.
 4,487,572 A 12/1984 Parker
 4,503,835 A 3/1985 Williams
 4,526,158 A 7/1985 Lee
 4,530,343 A 7/1985 Beck
 4,531,506 A 7/1985 Chambers
 4,559,921 A 12/1985 Benmussa
 4,621,608 A 11/1986 Lee
 4,692,168 A 9/1987 Dotson et al.
 4,708,122 A * 11/1987 Rock 126/43
 4,762,525 A 8/1988 Wood
 4,771,761 A * 9/1988 Doukhan et al. 126/263.09
 4,782,812 A 11/1988 Kellerman
 4,786,290 A 11/1988 Wyer
 4,793,320 A 12/1988 Bakic
 4,877,010 A 10/1989 Hait
 4,885,989 A 12/1989 Korpan
 4,896,653 A * 1/1990 Eke et al. 126/45
 4,899,721 A 2/1990 Tsay
 4,908,044 A * 3/1990 Brungardt 44/266

4,913,126 A 4/1990 McCall
 4,938,202 A 7/1990 Hait
 4,953,533 A 9/1990 Witt
 4,958,618 A 9/1990 Davidson
 4,969,449 A 11/1990 Levin
 5,024,208 A 6/1991 Hottenroth et al.
 5,054,265 A * 10/1991 Perigo et al. 53/425
 5,054,642 A * 10/1991 Yoshida 220/276
 D323,096 S 1/1992 Pack
 5,143,045 A 9/1992 Minnis
 5,143,046 A 9/1992 Koziol
 5,147,591 A * 9/1992 Yoshida 264/163
 5,184,421 A * 2/1993 Meharg 47/65.5
 5,193,521 A 3/1993 Levinson et al.
 5,211,105 A 5/1993 Liu
 5,257,616 A 11/1993 Koziol
 5,261,386 A 11/1993 Burkhardt
 5,302,114 A 4/1994 Kiefer et al.
 5,328,045 A * 7/1994 Yoshida 220/359.2
 5,359,988 A 11/1994 Hait
 5,395,005 A * 3/1995 Yoshida 220/359.2
 5,405,262 A 4/1995 Appel
 5,453,574 A 9/1995 Zuran et al.
 D363,191 S 10/1995 Gibson
 5,467,697 A 11/1995 Hunziker
 5,469,835 A 11/1995 Stephen et al.
 5,495,845 A 3/1996 Hait
 5,503,138 A 4/1996 Chang
 5,535,666 A 7/1996 Southerland
 5,535,733 A 7/1996 Hait
 5,584,283 A 12/1996 Messina
 5,638,743 A 6/1997 Lo
 5,641,890 A 6/1997 Wesley
 5,711,210 A 1/1998 Kaufman
 5,785,045 A 7/1998 Chen
 5,819,640 A 10/1998 Cuomo et al.
 5,832,915 A 11/1998 Skidmore et al.
 6,024,081 A 2/2000 Libertini, Jr.
 6,076,515 A 6/2000 Smith
 6,101,931 A 8/2000 Miklos
 6,158,425 A 12/2000 Kim
 6,205,912 B1 3/2001 Chiu
 6,591,828 B1 7/2003 Schneider
 6,606,987 B2 8/2003 DeMars
 6,644,298 B2 11/2003 Hermansen et al.
 6,755,877 B2 6/2004 Perlman
 D548,086 S * 8/2007 Conway et al. D9/732
 7,438,204 B2 * 10/2008 Conway et al. 222/486
 D592,445 S 5/2009 Sorenson et al.
 2003/0087212 A1 5/2003 Perlman
 2005/0220832 A1 * 10/2005 Walton 424/401
 2006/0219233 A1 10/2006 Sorenson et al.
 2006/0260598 A1 11/2006 Bjork et al.
 2008/0202489 A1 8/2008 Sorenson et al.

FOREIGN PATENT DOCUMENTS

WO WO 2008/106502 9/2008

OTHER PUBLICATIONS

International Search Report and Written Opinion for Application No. PCT/US2006/12525 dated Jun. 19, 2008 (6 pages).
 International Search Report and Written Opinion for Application No. PCT/US08/55107 dated Aug. 5, 2008 (7 pages).
 United States Office Action for U.S. Appl. No. 11/398,579 dated Nov. 25, 2008 (15 pages).

* cited by examiner

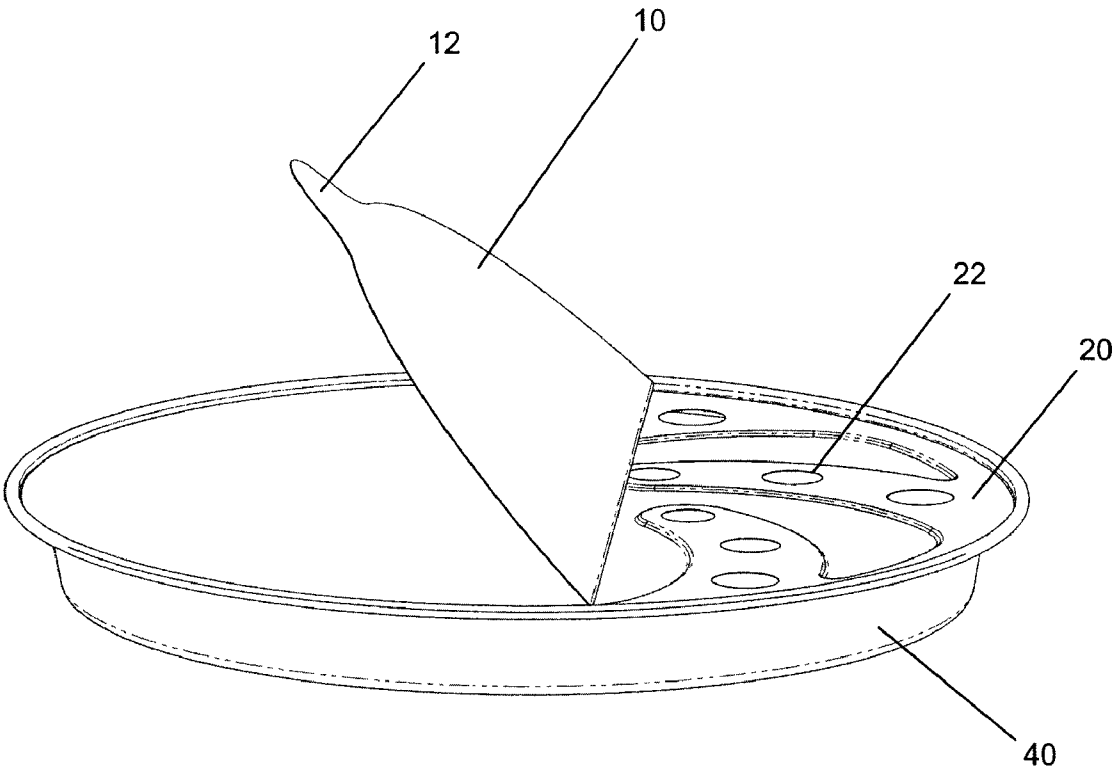

FIG. 1

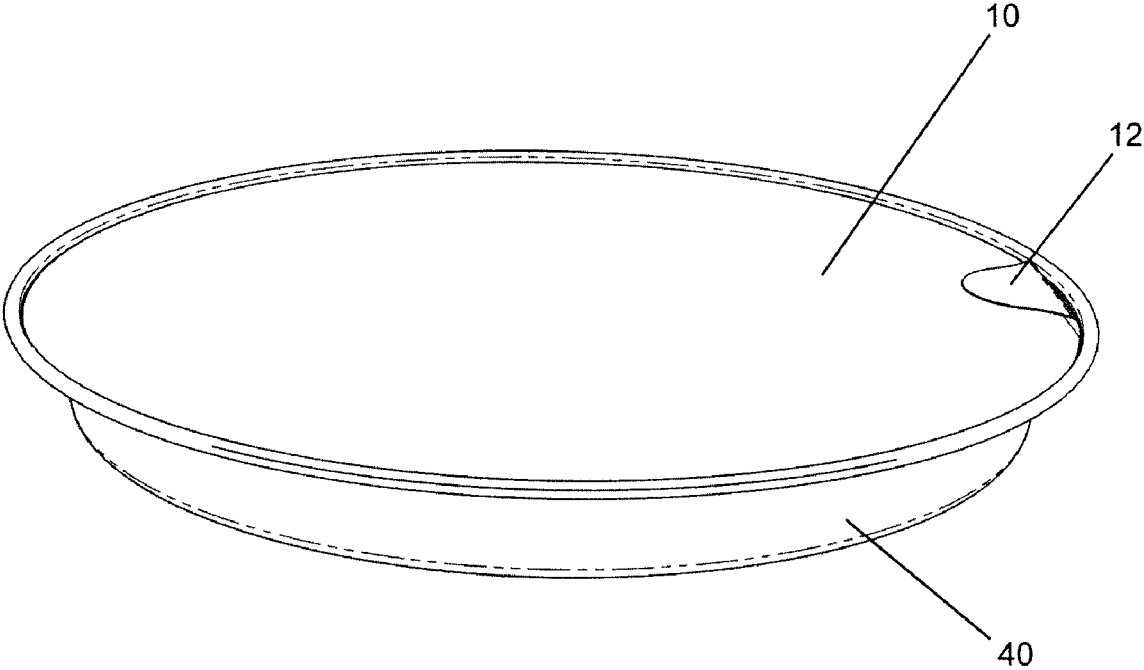

FIG. 2

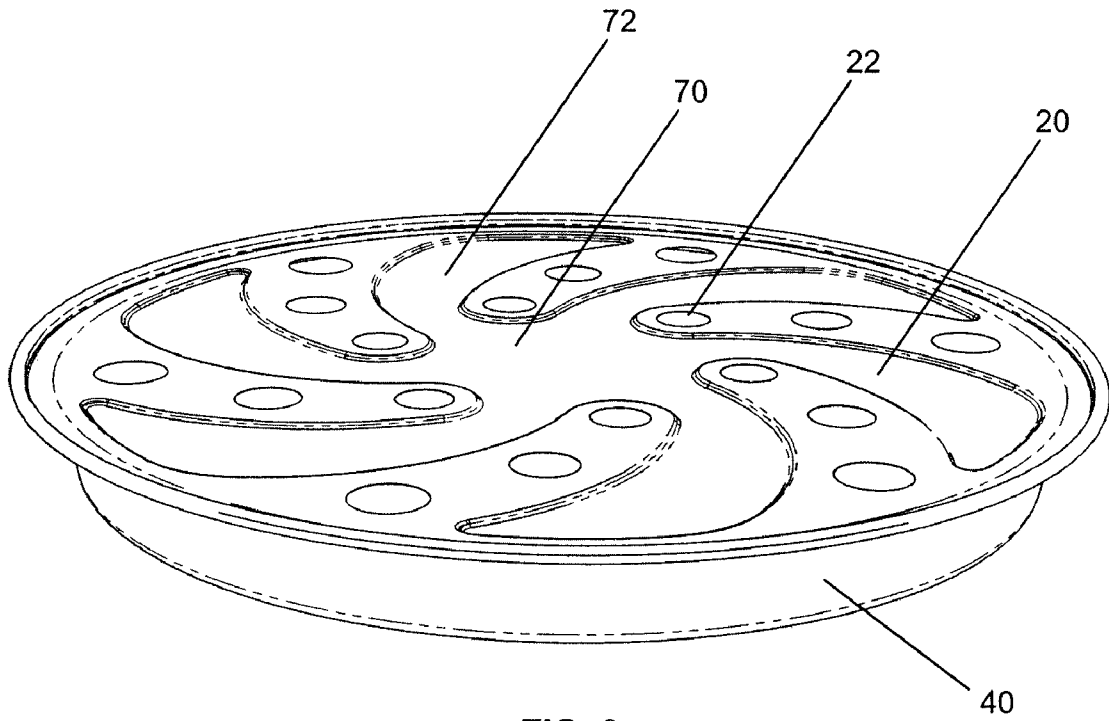

FIG. 3

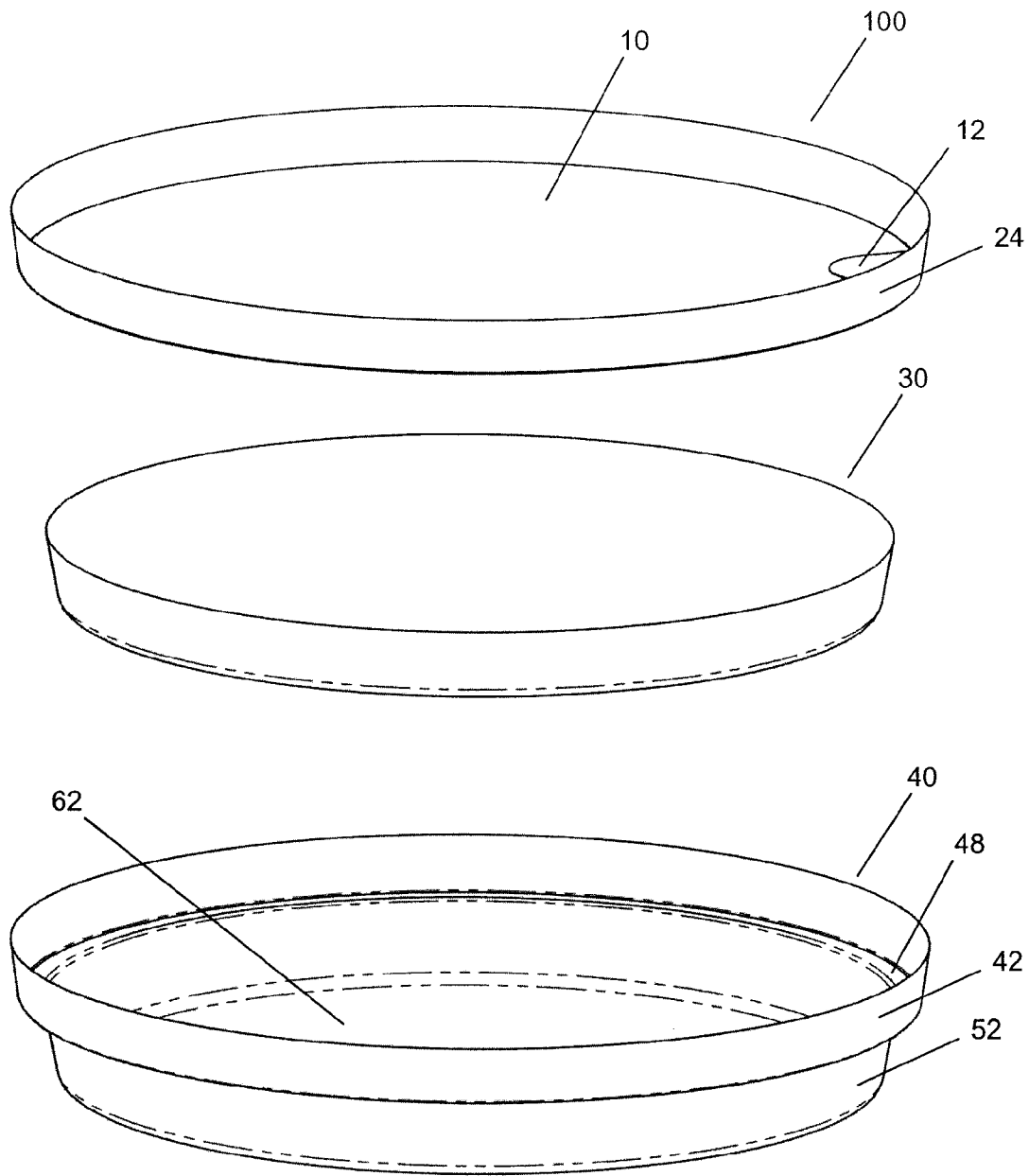

FIG. 4

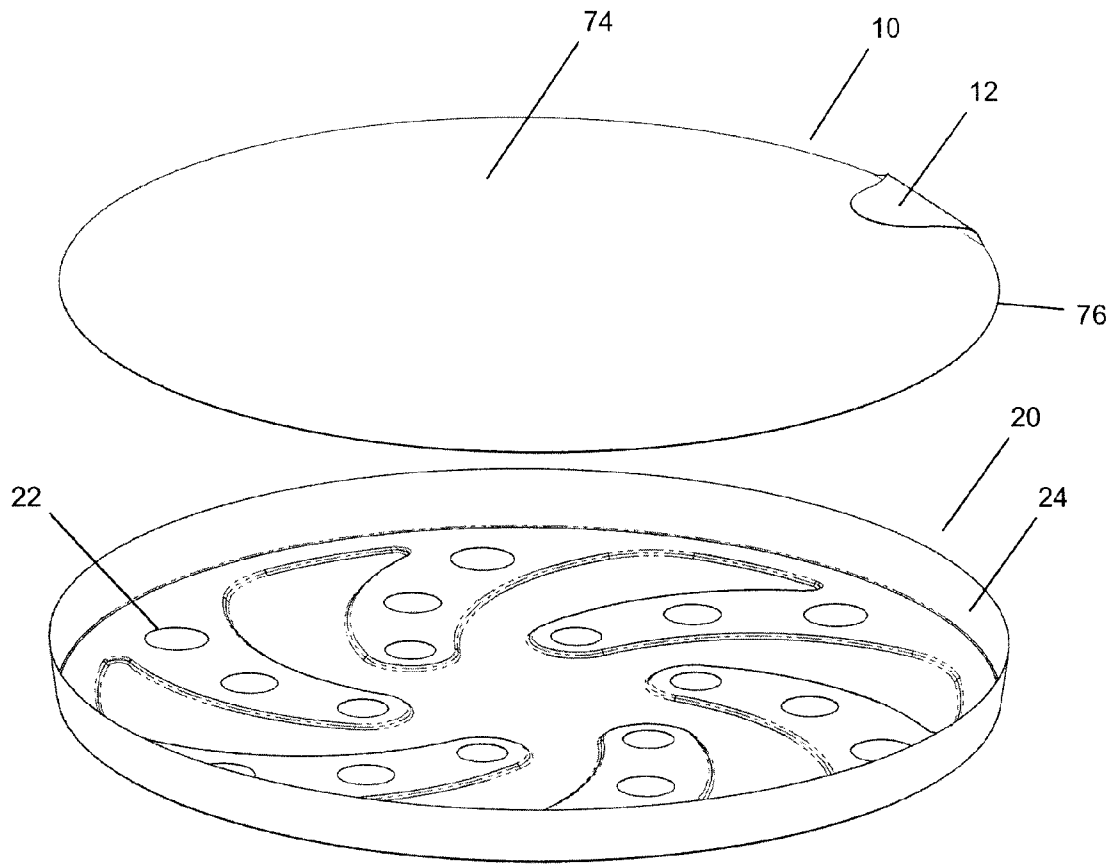
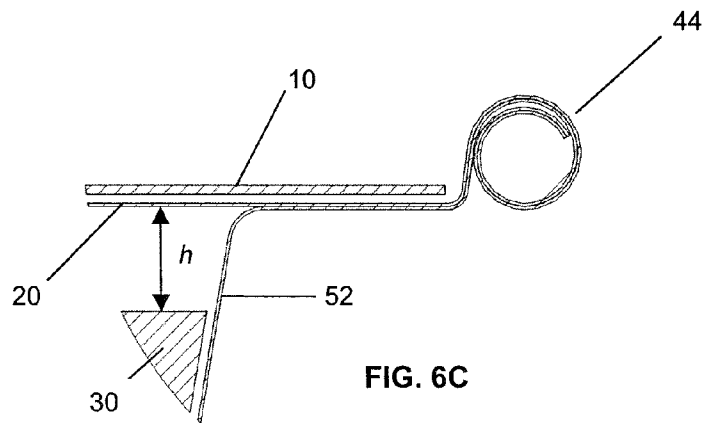
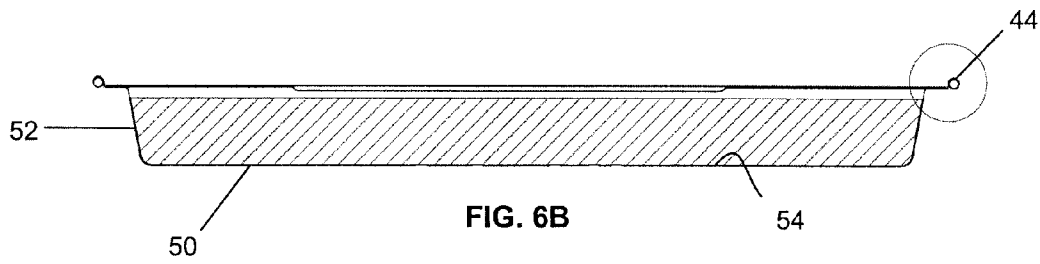
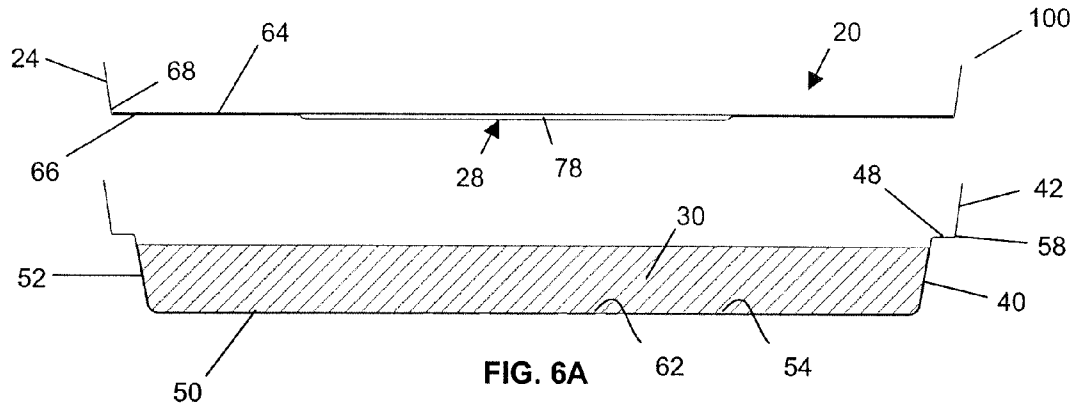

FIG. 5



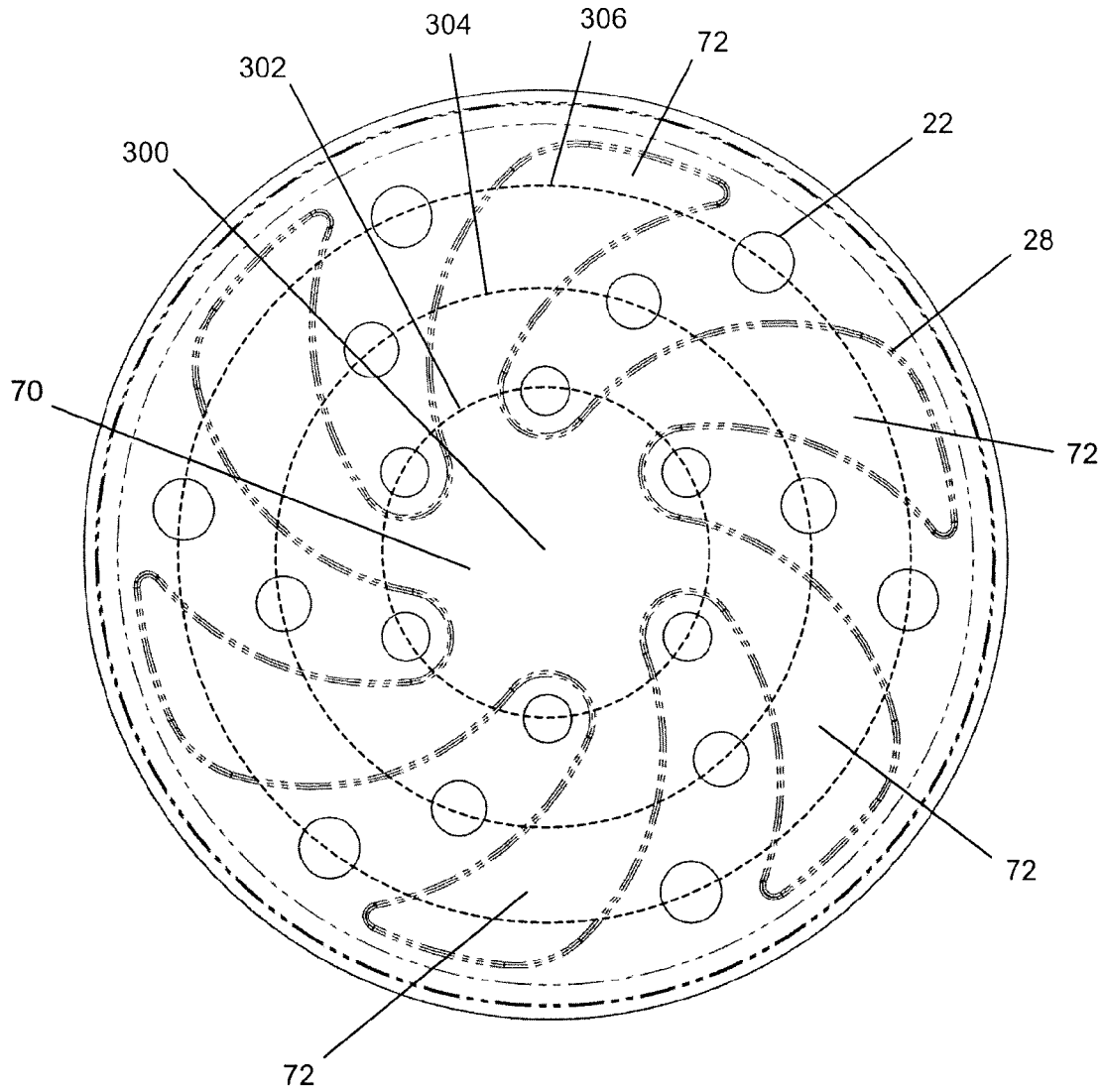

FIG. 7

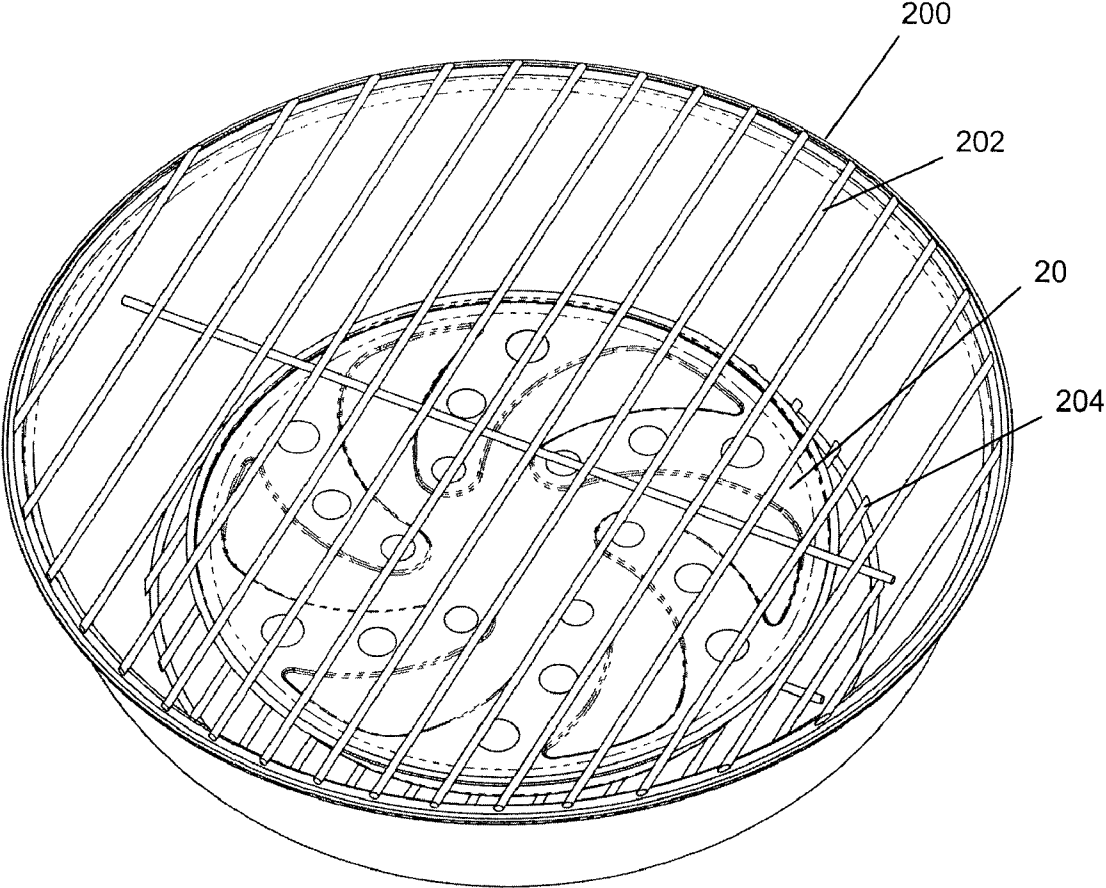

FIG. 8

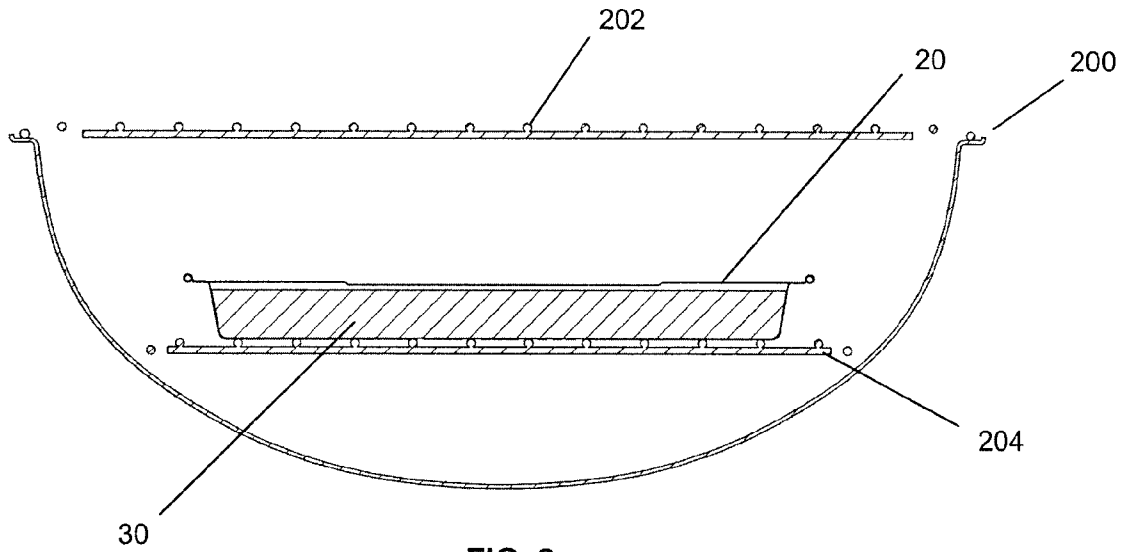
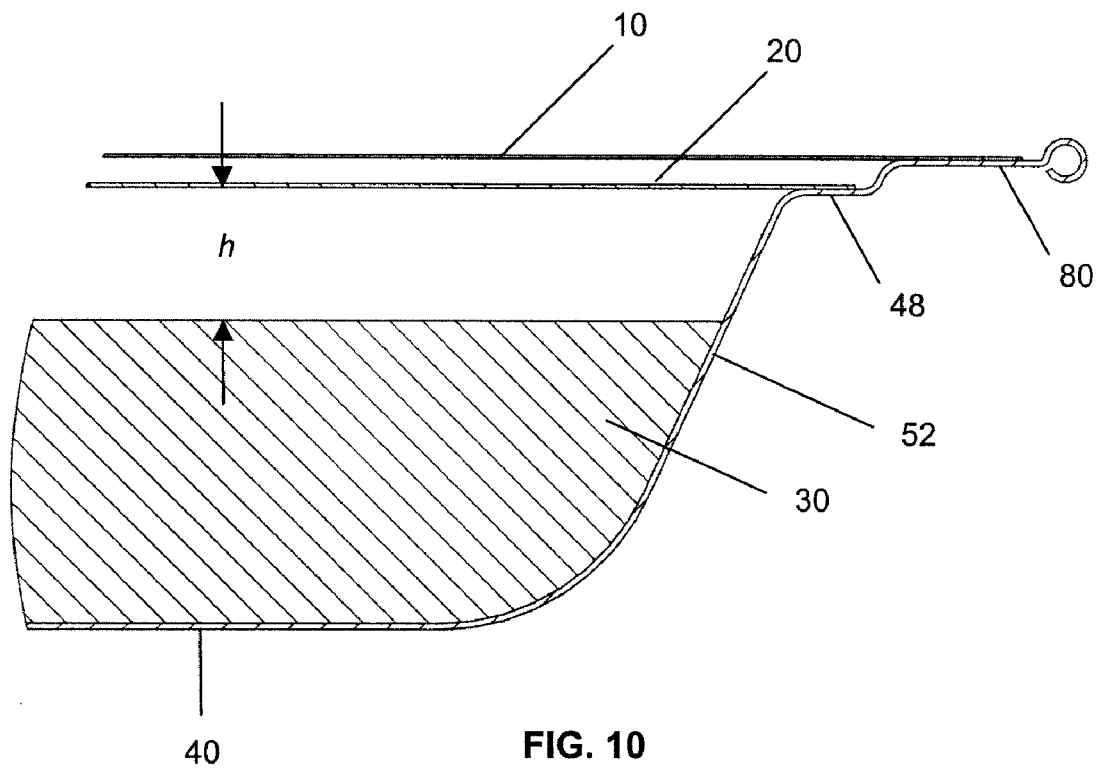

FIG. 9



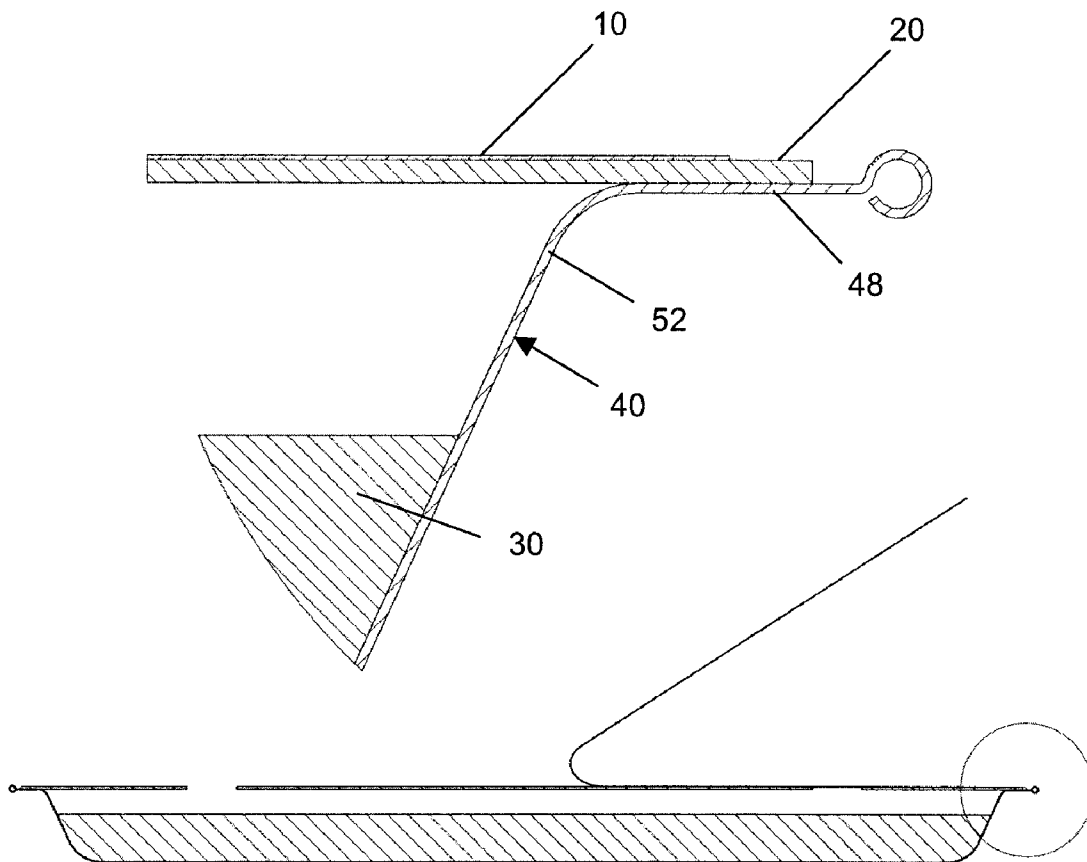

FIG. 11

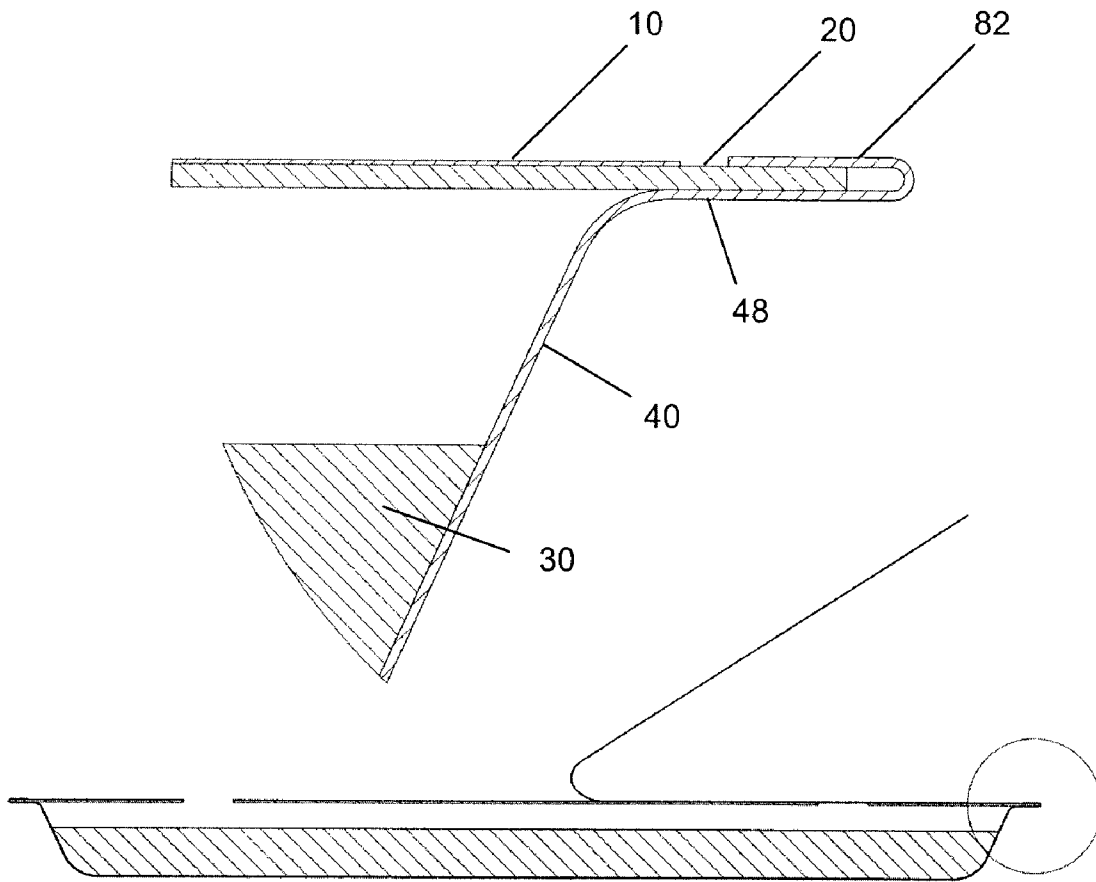

FIG. 12

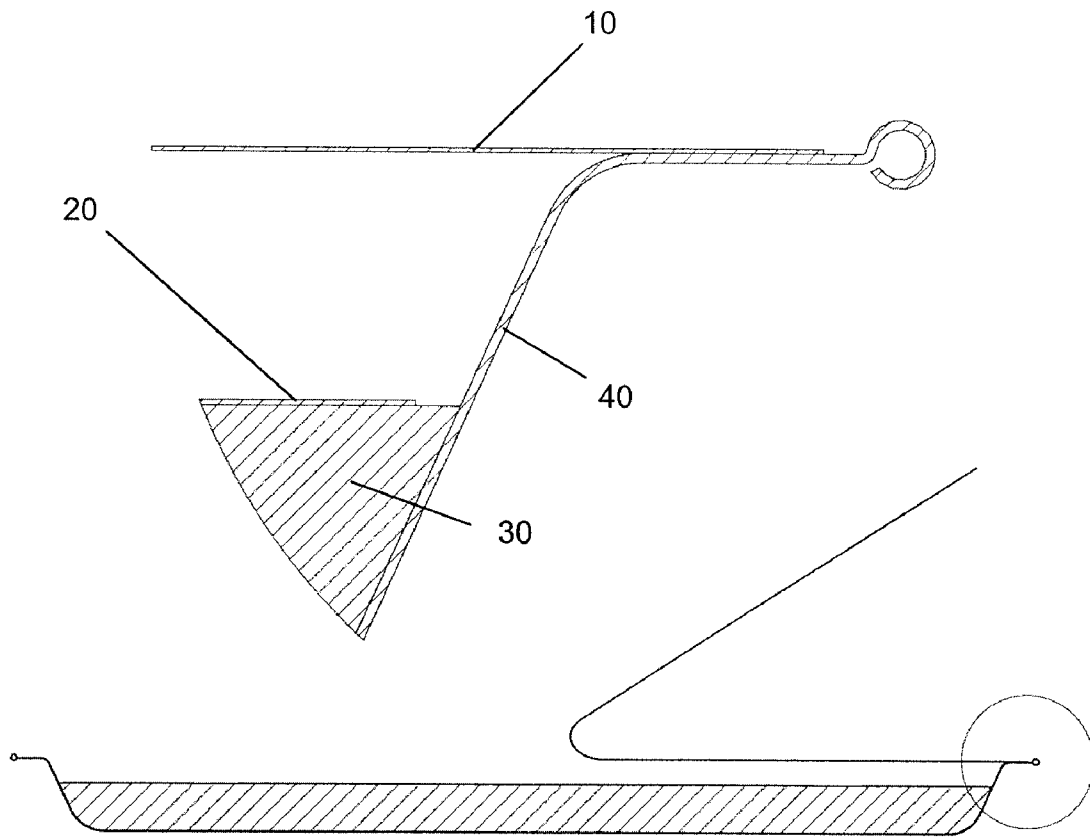

FIG. 13

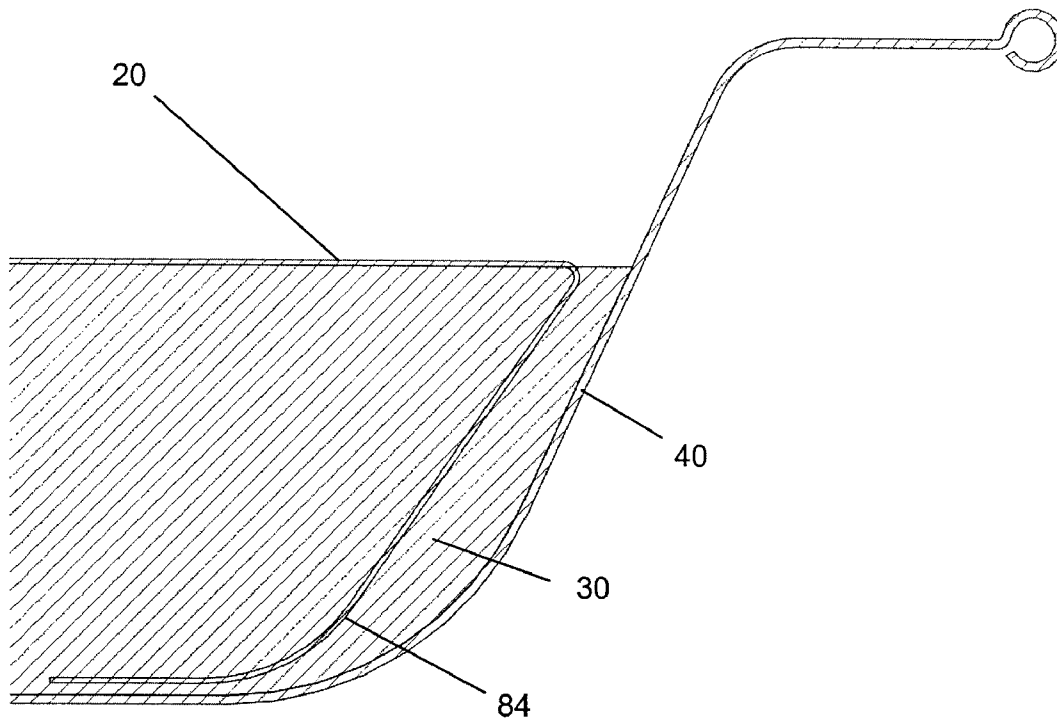

FIG. 14

INCLUSIVE SINGLE-USE HEATING DEVICE

CROSS REFERENCE TO RELATED APPLICATIONS

This application claims the benefit of priority to U.S. Provisional Patent Application No. 60/891,848 filed Feb. 27, 2007. This application is incorporated herein by reference in its entirety.

BACKGROUND OF THE INVENTION

Charcoal grills became popular after World War II and became synonymous with the "backyard barbeque" in America. In the United States alone, it is estimated that nearly \$800 million of charcoal was sold in 2006. Despite its popularity and pervasiveness, little innovation has taken place in this industry and all of the same problems associated with charcoal still remain.

Despite the broad appeal of charcoal grilling, grilling with charcoal fuel presents a number of problems including: requiring some type of intermediate ignition means, typically lighter fluid (petroleum distillates); requiring a long warm-up time (typically 30 minutes) prior to being suitable to cook over; having a long cool-down time (typically at least four hours) before the combustion has fully ceased and the grill can be safely cleaned or stored; being extremely messy, both from a set-up and clean-up standpoint, due to dirty combination of ash, soot, grease and other remains; generating significant amounts of carbon monoxide (a widely-known inhalation toxin); producing smoke and emissions that are an air quality and environmental concern; burning dirty and producing more polycyclic aromatic hydrocarbons (known carcinogens) relative to electric or gas grilling alternatives; being heavy and taking up a significant amount of space.

The present invention is new heat source for barbeque grills and other applications; specifically those grills that are fueled with traditional charcoal briquettes.

SUMMARY OF THE INVENTION

The present invention is a new heating device intended for charcoal grills that is a direct substitute for traditional charcoal. In one embodiment the device comprises a vessel, a fuel, and a combustion-restricting choke plate. In certain embodiments the heat source device also includes a hermetically sealed lidding.

In one embodiment, the vessel of the heating device has a bottom and a side wall, the bottom and side wall of the vessel forming an interior of the vessel. In one embodiment, the diameter of the bottom and the height of the side wall has a ratio of at least 8:1. The fuel of the heating device is placed in the interior of the vessel. In another embodiment, the vessel further has a support ledge that extends from the top of the side wall. In yet another embodiment, the vessel contains a vessel curl flange that extends upward from the outer edge of the support ledge.

The choke plate of the heating device of the invention has a top side, a bottom side, an outer edge and a plurality of apertures. In one embodiment, the plurality of apertures are arranged in concentric rings around the choke plate. In a further embodiment, the plurality of apertures comprise three separate concentric rings around the choke plate, consisting of an inner, a middle, and an outer ring, with the diameter of the apertures in the inner ring being smaller than the diameter of the apertures in the middle ring, and the diameter of the apertures in the middle ring being smaller than the diameter of

the apertures in the outer ring. In one embodiment of the invention the choke plate further has a depression section which has a bottom which is positioned lower than the bottom side of the choke plate. In one embodiment the depression section has a center section and a plurality of arm sections which extend towards the outer edge of the choke plate. In another embodiment the choke plate further contains a choke plate curl flange which extends upward from the outer edge of the choke plate. In this embodiment, a portion of the bottom side of the choke plate rests on the support ledge of the vessel and the vessel curl flange and the choke plate curl flange are curled together securing the choke plate to the vessel.

In certain embodiments the heat source device further comprises a lidding film having a top side and a bottom side. A portion of the bottom side of the lidding film is sealed to the top side of the choke plate.

In one embodiment the device can be used as follows: the user sets up his or her grill as usual and removes the lidding from the device to expose the choke-restricted fuel. The device is then placed in the grill instead of charcoal and the user ignites one of the exposed combustion apertures. Upon installing the grill's cooking grate, cooking can commence immediately.

BRIEF DESCRIPTION OF THE DRAWINGS

FIG. 1 is an assembled isometric view of the invention, showing the lidding 10 being removed.

FIG. 2 is an assembled isometric view of the invention, showing the lidding 10 still in place as it would be during shipping and storage.

FIG. 3 is an assembled isometric view of the invention, showing the lidding 10 fully removed and ready for use.

FIG. 4 is an exploded isometric view of the invention showing both the choke 20 and the vessel 40 in their pre-assembled, uncurled state.

FIG. 5 is an exploded isometric view of the choke lidding subassembly 100.

FIG. 6A is a cross-sectional exploded side view of the invention prior to curling the choke lidding subassembly 100 to the vessel 40.

FIG. 6B is a cross-sectional assembled side view of the invention fully assembled and the formation of the curl 44.

FIG. 6C is a detailed view of the cross-section of the invention showing the curl 44 formed between the choke lidding subassembly 100 and the vessel 40.

FIG. 7 is a plan view of the invention showing the combustion aperture 22 pattern and the choke emboss depression 28.

FIG. 8 is an isometric view of the invention being used inside of a common portable charcoal grill 200.

FIG. 9 is a cross-sectional side view of the invention being used inside of a grill 200.

FIG. 10 is a cross-section of one embodiment of the assembled invention.

FIG. 11 is a cross-section showing another embodiment of the packaging configuration.

FIG. 12 is a cross-section showing another embodiment of the packaging configuration.

FIG. 13 is a cross-section showing another embodiment of the packaging configuration.

FIG. 14 is a cross-section showing another embodiment of the packaging configuration.

Before the embodiments of the invention are explained in detail, it is to be understood that the invention is not limited in its application to the details of construction and the arrangements of the components set forth in the following description or illustrated in the drawings. The invention is capable of

other embodiments and of being practiced or being carried out in various ways. Also, it is understood that the phraseology and terminology used herein are for the purpose of description and should not be regarded as limiting. The use of “including”, “having” and “comprising” and variations thereof herein is meant to encompass the items listed thereafter and equivalents thereof as well as additional items and equivalents thereof.

It also is understood that any numerical value recited herein includes all values from the lower value to the upper value. For example, if a concentration range is stated as 1% to 50%, it is intended that values such as 2% to 40%, 10% to 30%, or 1% to 3%, etc., are expressly enumerated in this specification. These are only examples of what is specifically intended, and all possible combinations of numerical values between the lowest value and the highest value enumerated are to be considered to be expressly stated in this application.

DETAILED DESCRIPTION OF THE INVENTION

The present invention provides a single-use heating device that utilizes a non-charcoal fuel source that is pre-assembled and ready to use. The heating device is intended to be used within an existing grill and serves as a direct replacement for charcoal in charcoal grills. Alternatively, it can also be used within propane grills as a substitute for propane. This mode of use is particularly useful as a back-up fuel source when the propane inadvertently runs empty and no additional propane is conveniently available. The heating device can be used for a wide variety of applications beyond grilling as well, including boiling water or providing a heat source for a shore lunch, to name a couple. Suitably, the heating device requires no additional components beyond food and some means for food support, most often a standard charcoal grill, for a complete cooking session. Suitably, the fuel utilized is a solid alcohol, which is clean-burning, inexpensive and does not require the use of intermediate tinder material to achieve self-sustaining combustion. In this way, the user may directly ignite the base fuel and does not have to wait for the heat source to reach a suitable temperature to begin cooking, which is otherwise typical with more traditional wood or charcoal fuels. This allows the user to experience very little delay between ignition and actual cooking.

One embodiment of the invention is shown in FIGS. 1-9. In this embodiment the device is comprised of four main components: a vessel 40, fuel 30, a choke plate 20 and lidding film 10.

Suitably, the vessel 40 is fabricated from a thin sheet of metal. In one embodiment the thickness can be 0.004 in. thick aluminum. The vessel 40 contains comprises a bottom 50 and side wall 52 extending up from and surrounding the bottom 50 of the vessel 40. The bottom 50 and side wall 52 of the vessel 40 form the interior 62 of the vessel 40. The vessel 40 also has a top 54 off of which a support ledge 28 extends from. The support ledge 48 has an outer ledge 58 and is designed to support a portion of the choke plate 20. The vessel 40 also has a vessel curl flange 42 which extends upward from the outer edge 58 of the support ledge 48.

The fuel 30 is placed in the interior 62 of the vessel 40. The fuel 30 provides the heat content of the device through combustion and can be any clean burning volatile fuel, such as a solidified alcohol. In one embodiment the fuel comprises a solidified ethanol, water and sodium stearate mixture. Suitably ethanol is at least 55% w/v of the mixture. More suitably ethanol is present in an amount of between 80-95% w/v of the mixture. Water is suitably present in the mixture in an amount of 0-40% w/v, more suitably in an amount of 3-14% w/v, and

even more suitably in an amount of 3-4% w/v. Sodium stearate is suitably present in the mixture in an amount of 2-20% w/v. More suitably, sodium stearate is present in an amount between 2-10% w/v of the mixture. In one embodiment the fuel mixture comprises a mixture of 90% ethanol, 7% sodium state and 3% water. The ratios of these components can be varied to achieve different performance attributes. For instance, reducing the amount of sodium stearate in the formula correspondingly reduces the amount of post-combustion residue that remains in the device.

Alternatively, the fuel 30 can utilize a polymer rheology modifier, such as Carbopol (available from Noveon, Inc), to increase the viscosity of the ethanol and water solution to a suitable viscosity. These processes are well known in the prior art for thickening alcohol-based fuel, such as U.S. Pat. No. 5,641,890, incorporated herein by reference.

Alternatively, the fuel 30 can also utilize nitrocellulose to achieve a gelled state. U.S. Pat. No. 3,183,068, incorporated herein by reference, describes how nitrocellulose can be used to gel alcohol. The alcohol does not need to be heated for this process.

The fuel 30 can also be any of the lower-carbon alcohols, such as methyl alcohol (methanol), ethyl alcohol (ethanol) or isopropyl alcohol (isopropanol). Ethanol has the advantage of being less toxic than methanol or isopropanol from an ingestion standpoint, but all burn extremely clean and are completely safe to cook over.

The choke plate 20 can be made from any non-combustible material. In one embodiment the choke is made from 0.004 in. thick aluminum foil. The choke plate 20 has a top side 64, a bottom side 66, an outer edge 68, and a plurality of apertures 22. The choke plate 20 restricts the combustion of the fuel 30 down to a predetermined rate through varying the size, position and number of the apertures 22 present in the design. Generally speaking, the higher the cumulative exposed surface area of the fuel 30, the faster the combustion rate. The size and number of aperture 22 can be adjusted to provide the exposed surface area that is desired for the heating characteristics of the device. For direct cooking applications, suitably the combined plurality of apertures 22 provide a cumulative exposed surface area of the fuel (i.e. the cumulative combined area of the apertures) of greater than about 4-5 square inches, though different cumulative exposed surface areas can be used depending on the cooking characteristics desired. FIG. 7 describes one such choke aperture 22 pattern, but an infinite number of patterns are feasible. In the embodiment shown in FIG. 7 the plurality of apertures 22 are arranged in concentric rings around the center 300 of the choke plate. The plurality of apertures 22 comprise three separate concentric rings around the choke plate, consisting of an inner ring 302, a middle ring 304, and an outer ring 306. The diameter of the apertures in the inner ring 302 are smaller than the diameter of the apertures in the middle ring 304, and the diameter of the apertures in the middle ring 304 are smaller than the diameter of the apertures in the outer ring 306. In one embodiment, the apertures 22 of the inner ring 302 are 1/2" in diameter, the apertures 22 of the middle ring 304 are 3/16" in diameter and the apertures 22 of the outer ring 306 are 5/8" in diameter. This type of arrangement is pursued in one embodiment when one desires to bias the heat output of the device to the perimeter of the device to achieve a grillable surface beyond the perimeter of the apertures and to counteract a natural tendency for the inner holes to burn faster (if they were equivalent surface area) due to the natural air currents that are established where air circulates in from the perimeter radially and meets in the center. The choke plate 20 perimeter profile and combustion aperture 22 pattern can both be quickly fabricated in a singu-

lar step with a standard shear cutting press process that occurs simultaneous with its forming process.

A portion of the bottom side **66** of the choke plate **20** is supported by the vessel support ledge **48** on the vessel **40**. See FIGS. 6A-C. The choke plate **20** also features a choke plate curl flange **24** that extends upward from the outer edge **68** of the choke plate **20**. The choke plate **20** and the vessel **40** have matching curl flange regions (**42** and **24**), which are substantially vertical with a slight amount of draft to permit efficient nesting when stored in their sub-component state. When assembled the vessel curl flange **42** and the choke plate curl flange **24** are curled together securing the choke plate **20** to the vessel **40**.

The choke plate **20** also features a depression section **28** which has a bottom **78** which is positioned lower than the bottom side **66** of the choke plate **20**. The depression section **28** can be embossed into the choke plate **20**. In one embodiment the depression section **28** has a center section **70** and a plurality of arm sections **72** which extend towards the outer edge **68** of the choke plate **20**. In one embodiment no apertures **22** are located in the depression section **28**. The depression section **28**, among other purposes, adds aesthetic interest to the device for marketing appeal, strengthens the choke **20**, and elevates the combustion apertures **22** slightly above the plane where grease drippings accumulate when grilling particularly greasy food, such as 80% lean ground beef (which helps to prevent excessive intermingling of the grease with the fuel **30**).

The lidding film is suitably made from a thin film of paper or aluminum foil which has an adhesive or heat seal layer. Suitably the lidding film can be from 1-10 mm in thickness, though any suitable desired thickness can be used. The lidding film **10** has a top side **74** and a bottom side **76**. The lidding film **10** provides a removable vapor barrier between the interior of the device and the environment, thus preserving the volatile fuel vapors from escaping. The lidding film **10** is suitably heat sealed to the choke plate **20** around the perimeter of the lidding film with an approximate $\frac{3}{16}$ " seal width, which creates a hermetic and impermeable package. The chosen heat sealant must exhibit enough adhesion to withstand common end-user abuse, transit and storage across a broad range of environments, but no so much that would make easy removal by the end-user difficult. Packaging solutions that involve hermetic and simultaneous "peel-away" characteristics are widely known and used in the packaging industry for food products. Alternatively, pressure sensitive adhesives can be used instead of heat sealing.

The lidding film **10** can feature a peel-away tab **12** that is folded 180 degrees back onto the top surface of the lidding film **10**, which provides a convenient area for the user to grip the lidding and initiate the peel-away process upon use of the device. The lidding film **10** can also be printed with marketing graphics, instructions and product-use warnings and therefore serves a communication function, in addition to its vapor barrier role.

In another embodiment, shown in FIG. 10, the lidding film **10** is sealed directly to the vessel **40**. In this embodiment, the vessel **40** has a sealing flange **80** that is sufficiently flat, smooth and free of residue to provide a suitable surface to heat-seal or otherwise bond the lidding film **10** to the vessel **40** hermetically. The sealing flange **80** is positioned on the side wall **52** of the vessel **40**, above the choke support ledge **48**. A hermetic seal between the lidding film **10** and the vessel **40** can be used to preserve the volatile alcohol-based fuel **30**.

In another embodiment, the choke plate **20** is directly sealed to the choke plate support ledge **48** of the vessel **40**. One of these embodiments is shown in FIG. 11. The choke

plate **20** is directly sealed to the sealing flange **80** of the vessel **40**. This provides the further benefit of maximizing the combustible surface area of the device without increasing the major dimensions of the vessel **40**. A hermetic seal is used between both the choke plate **20**/support ledge **48** interface, and the choke plate **20**/lidding film **10** interface. The assembly sequence can be reordered for this embodiment, whereby the lidding film **10** can be pre-applied to the choke plate **20** in a subassembly. Filling the vessel **40** with fuel **30** can be performed first, and then secondarily the entire choke plate **20**/lidding **10** film subassembly can be either heat-sealed or glued to the support ledge **48** of the vessel **40**. Another embodiment where the choke plate **20** is sealed directly to the vessel **40** is shown in FIG. 12. In this embodiment the vessel **40** contains some added material around the perimeter of the side wall **52**, a fold-over flange **82**. The product is assembled in the same fashion mentioned above and the fold-over flange **82** is crimped over the top of the choke plate **20** to add mechanical integrity to the choke plate **20**/vessel **40** interface. This embodiment is particularly conducive to a vessel **40** that may be manufactured with what is referred to as a "crinkle-wall" process. The added material of the fold-over flange **82** coupled with the use of an adhesive ensures the interface is hermetic. A "crinkle-wall" process is attractive economically because both upfront tooling expenses and variable part costs are significantly lower than corresponding "smooth-wall" processes.

In another embodiment, the choke plate **20** is simply laid on top of the fuel **30**. This embodiment is shown in FIG. 13. This approach preserves the geometric simplicity of the vessel **40**, since no choke support ledge **48** is needed, and at the same time avoids the need for two hermetic seals in the design. In this embodiment the fuel **30** is dispensed into the vessel **40** first and then the choke plate **20** is installed secondarily.

In yet another embodiment the choke plate is support by choke legs **84**. This embodiment is shown in FIG. 14. These choke legs **84** can rest on the bottom **50** of the vessel, be directly attached or integral to the vessel, or can be embedded in the fuel **30**. These choke legs can support the choke plate **20** while fuel is dispensed and mechanically secure the choke plate **20** within the fuel **30** after cooling/curing.

Suitably the diameter of the bottom **50** of the vessel **40** is greater than the height of the side wall **52** of the vessel **40**. Suitably the diameter of the bottom **50** and the height of the side wall **52** has an aspect ratio of at least 8:1 (diameter of bottom of vessel:height of side wall). This aspect ratio has an impact on the burn characteristics of the device. Larger fuel surface areas lead to faster combustion rates because there is a larger surface to absorb thermal feedback and emit alcohol gas into the headspace region between the top surface of the fuel and the choke. This surface area can be adjusted along with other parameters to achieve the desired combustion rate.

In one embodiment, the present invention is assembled by placing the lidding film **10** onto the top surface **64** of the choke **20** plate within the cavity defined by the choke curl flange **24**, ensuring the printed side faces upward and the sealant side faces downward. The two components are then placed inside heat sealing equipment and actuated. Typically heat is applied through the top surface **74** of the lidding film **10** at the perimeter in a continuous and uninterrupted fashion using an optimized combination of temperature, dwell time and pressure to achieve a seal with the appropriate characteristics. Once the two components are bonded together in this way, the resulting sub-assembly is referred to as the choke lidding subassembly **100**.

Separately, the vessel **40** can be filled with fuel **30** using a shot metering system that dispenses a precise volumetric quantity, suitably 500 mL. The fuel **30** self-levels and solidifies, at which time the choke lidding subassembly **100** is installed by seating the choke plate **20** onto the vessel **40**, so that the choke plate curl flange **24** mates with the vessel curl flange **42**. The underside of the choke plate **20** is directly supported by the support ledge **48** on the vessel **40**. The entire device is then put inside a curling machine that curls the vessel curl flange **42** and the choke plate curl flange **24** simultaneously together to form the curl **44**. The curl **44** mechanically connects the choke **20** to the vessel **40**, provides a hermetic interface and dramatically strengthens the device.

The headspace (dimension *h*) present in the design between the top surface of the fuel **30** and the choke plate **20** allows the device to be lit completely from a single combustion aperture. The headspace (dimension *h*) further allows the device to burn more robustly throughout the combustion duration; if one or more of the combustion apertures **22** goes out temporarily, it is quickly re-ignited by adjacent combustion of the other combustion apertures **22** via the air gap between the fuel **30** and the choke **20**.

Upon use, the user pinches the peel-away tab **12** and peels away the lidding **10**, exposing the choke plate **20** and exposed portions of fuel **30** that are visible through the combustion aperture **22** pattern. See FIG. **8**. The device is placed in the bottom of a traditional grill **200** on the support grate **204**, where charcoal is typically placed. The user then lights the product by igniting one of the combustion apertures **22** and then installs the cooking grate **202**. Grilling can commence immediately. The grill lid may or may not be used, with little difference in performance or cook rate; however some smaller grills do not provide sufficient oxygen ventilation to sustain combustion and therefore this practice is generally not recommended. Using the device without a grill lid does not compromise the product's performance whatsoever because of the direct contact that occurs intermittently between the flames and the food. Periodic turning of the food to cook both sides equally speeds the cooking process and ensures uniform cooking.

At the conclusion of the grilling session, typically 45 minutes, the product fully consumes the fuel **30** and extinguishes. Within seconds, the device is cool-to-the-touch and can be safely removed and discarded. The present invention requires no intermediate tinder material (such as lighter fluid), heats instantly and cools down very rapidly. Due to its low level of residue and aluminum construction, the device can be recycled in a similar fashion as aluminum beverage cans.

While the present invention has now been described and exemplified with some specificity, those skilled in the art will appreciate the various modifications, including variations, additions, and omissions that may be made in what has been described. Accordingly, it is intended that these modifications also be encompassed by the present invention and that the scope of the present invention be limited solely by the broadest interpretation that lawfully can be accorded the appended claims.

The invention claimed is:

1. A grilling device comprising:

a vessel having a bottom; a side wall extending up from the bottom, the side wall having a top; wherein the bottom and side wall of the vessel form an interior of the vessel; an alcohol fuel located in the interior of the vessel, wherein the alcohol fuel is solidified and consists of a mixture of ethanol, water and sodium stearate;

a choke plate having top side, a bottom side, a plurality of apertures;

wherein the choke plate is secured to the vessel; and wherein the bottom of the vessel has a diameter and the side wall of the vessel has a height; and wherein the diameter of the bottom of the vessel and the height of the side wall have an aspect ratio of at least 8:1.

2. The grilling device of claim **1** further comprising a lidding film having a top side, a bottom side, wherein a portion of the bottom side of the lidding film is sealed to the top side of the choke plate.

3. The grilling device of claim **1** wherein the vessel further has a support ledge having an outer edge, the support ledge extending from the top of the side wall; and wherein a portion of the bottom side of the choke plate rests on the support ledge of the vessel.

4. The grilling device of claim **3** wherein the vessel further has a vessel curl flange extending upward from the outer edge of the support ledge;

wherein the choke plate further has an outer edge and a choke plate curl flange which extends upward from the outer edge of the choke plate; and

wherein the vessel curl flange and the choke plate curl flange are curled together securing the choke plate to the vessel.

5. The grilling device of claim **1** wherein the choke plate has a center and the plurality of apertures in the choke plate are arranged in concentric rings around the center of the choke plate.

6. The grilling device of claim **5** wherein each aperture has a diameter and wherein the plurality of apertures are arranged in three separate concentric rings around the center of the choke plate, the three concentric rings comprising an inner ring, a middle ring, and an outer ring; wherein the diameter of the apertures in the inner ring are smaller than the diameter of the apertures in the middle ring, and the diameter of the apertures in the middle ring are smaller than the diameter of the apertures in the outer ring.

7. The grilling device of claim **1** wherein the ethanol in the fuel is present in an amount of at least 55% w/v of the mixture; water is present in an amount of 0-40% w/v of the mixture; and sodium stearate is present in an amount of 2-20% w/v of the mixture.

8. The grilling device of claim **7** wherein the ethanol in the fuel is present in an amount of 80-95% w/v of the mixture; water is present in an amount of 3-4% w/v of the mixture; and sodium stearate is present in an amount of 2-10% w/v of the mixture.

9. A grilling device comprising:

a vessel having a bottom; a side wall extending up from the bottom, the side wall having a top; wherein the bottom and side wall of the vessel form an interior of the vessel; an alcohol fuel located in the interior of the vessel, wherein the alcohol fuel is solidified and consists of a mixture of ethanol, water and sodium stearate;

a choke plate having a top side, a bottom side, an outer edge, a plurality of apertures, wherein the choke plate is secured to the vessel;

wherein the choke plate has a center and the plurality of apertures in the choke plate are arranged in concentric rings around the center of the choke plate; and

wherein each aperture has a diameter and wherein the plurality of apertures are arranged in three separate concentric rings around the center of the choke plate, the three concentric rings comprising an inner ring, a middle ring, and an outer ring; wherein the diameter of the apertures in the inner ring are smaller than the diameter of the apertures in the middle ring, and the diameter of

9

the apertures in the middle ring are smaller than the diameter of the apertures in the outer ring.

10. The grilling device of claim **9** wherein the ethanol in the fuel is present in an amount of at least 55% w/v of the mixture; water is present in an amount of 0-40% w/v of the mixture; and sodium stearate is present in an amount of 2-20% w/v of the mixture.

11. The grilling device of claim **10** wherein the ethanol in the fuel is present in an amount of 80-95% w/v of the mixture; water is present in an amount of 3-4% w/v of the mixture; and sodium stearate is present in an amount of 2-10% w/v of the mixture.

12. A grilling device comprising:

a vessel having a bottom; a side wall extending up from the bottom, the side wall having a top; wherein the bottom and side wall of the vessel form an interior of the vessel; a fuel located in the interior of the vessel;

a choke plate having a top side, a bottom side, an outer edge, a plurality of apertures, and a depression section which has a depression section bottom which is positioned lower than the bottom side of the choke plate; wherein the choke plate is secured to the vessel;

wherein the choke plate has a center and the plurality of apertures in the choke plate are arranged in concentric rings around the center of the choke plate; and

wherein each aperture has a diameter and wherein the plurality of apertures are arranged in three separate concentric rings around the center of the choke plate, the

10

three concentric rings comprising an inner ring, a middle ring, and an outer ring; wherein the diameter of the apertures in the inner ring are smaller than the diameter of the apertures in the middle ring, and the diameter of the apertures in the middle ring are smaller than the diameter of the apertures in the outer ring.

13. The grilling device of claim **12** wherein the vessel further has a support ledge having an outer edge, the support ledge extending from the top of the side wall; and wherein a portion of the bottom side of the choke plate rests on the support ledge of the vessel.

14. The grilling device of claim **13** wherein the vessel further has a vessel curl flange extending upward from the outer edge of the support ledge;

wherein the choke plate further has a choke plate curl flange which extends upward from the outer edge of the choke plate; and

wherein the vessel curl flange and the choke plate curl flange are curled together securing the choke plate to the vessel.

15. The grilling device of claim **12** wherein the have a cumulative combined area of 4-5 square inches.

16. The grilling device of claim **12** wherein the bottom of the vessel has a diameter and the side wall of the vessel has a height; and wherein the diameter of the bottom of the vessel and the height of the side wall have an aspect ratio of at least 8:1.

* * * * *