

ORION STOVE & STAND

THE • ION • ALTERNATIVE

'Get it? "OR"-ion, the Ion Alternative?
'Anyway, credit for the original Ion Stove goes to Sgt. Rock, www.hikinghq.net.



ONLY 2 GRAMS



Make your own!

You will need:

- a Guinness or similar can
- scissors
- tape
- the template provided on this page

- 1 Cut out the template along the rectangular dotted line.
- 2 Wrap the template around the can, tape the ends together where they overlap, position the template where you want it on the can, then tape it in position.
- 3 Staying at least 1/8" away from the outline of the pot stand on the template, punch the bottom blade of the scissors through the template and the can, then **roughly** cut out the stand.
- 4 Cutting through the paper template and the can at the same time, cut out the stand along the solid line on the template.
- 5 Without making hard creases, bend the paper and can between your thumbnail and fingertip along the dotted lines.
- 6 Remove the template, smooth the creases, round off sharp corners and trim any burrs off the edges.

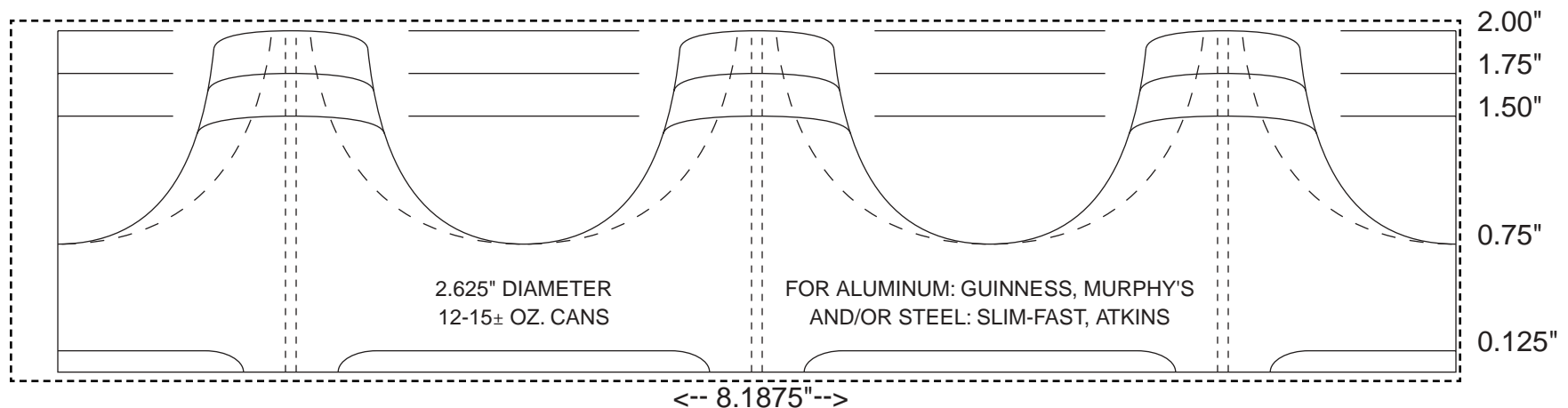

(Check this dimension with a ruler and turn off "scale to fit page" in your printer settings if necessary.)